



Vortex Submersible Pump

VX80T2.942



Vortex Submersible Pump

VX80T2.942



Construction features

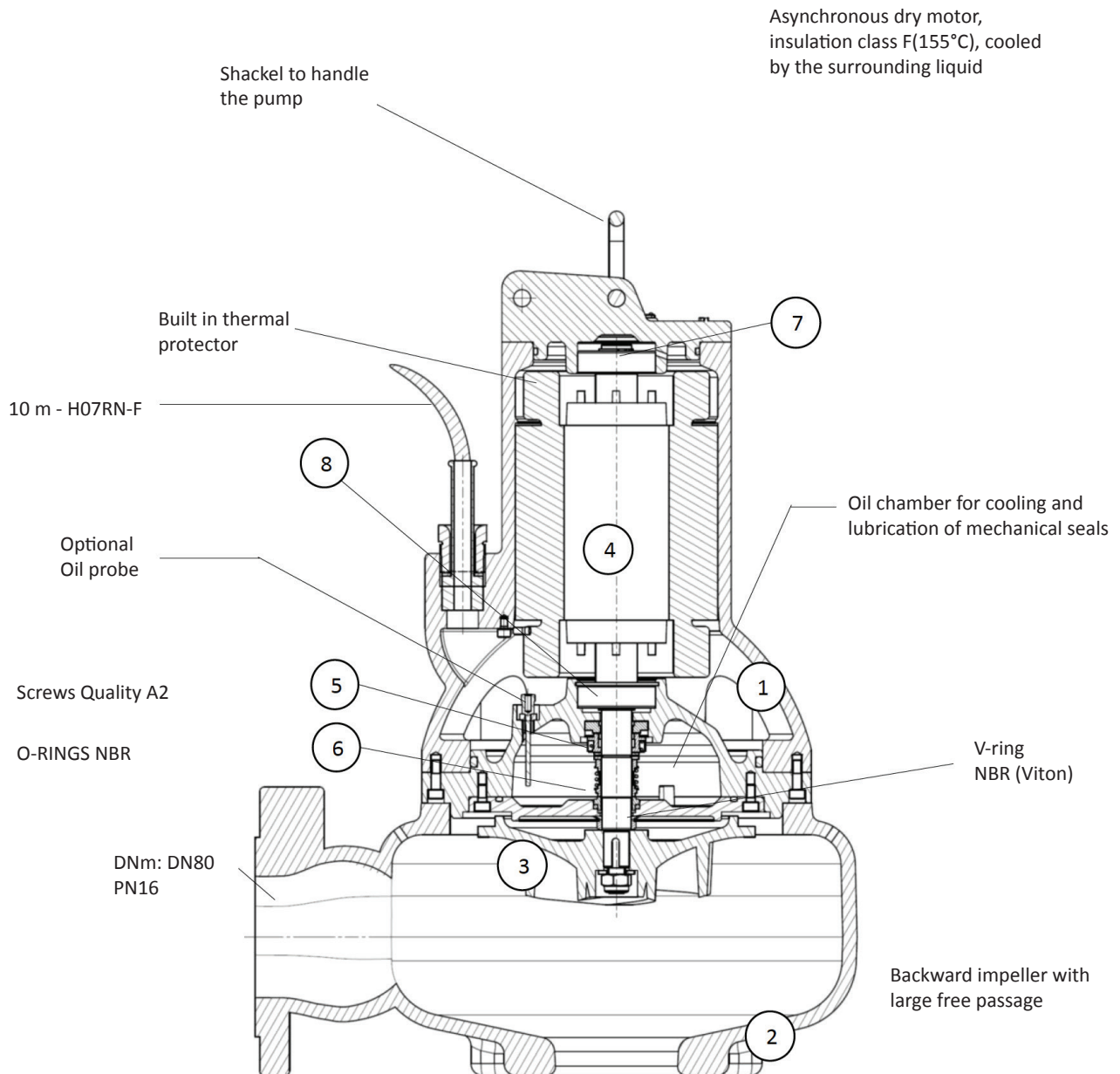

No.	Description	Material
1	Motor group	Cast iron
2	Cover	Cast iron
3	Self cleaning propeller	Cast iron
4	Shaft	AISI 420B

No.	Description	Material
5	Upper mech. seal	Carbon/Graphite/NBR
6	Lower mech. seal	SiC/SiC/NBR
7	Top bearing	6302-2RS
8	Lower bearing	6304-2RS

Vortex Submersible Pump

VX80T2.942



PERFORMANCE CURVE

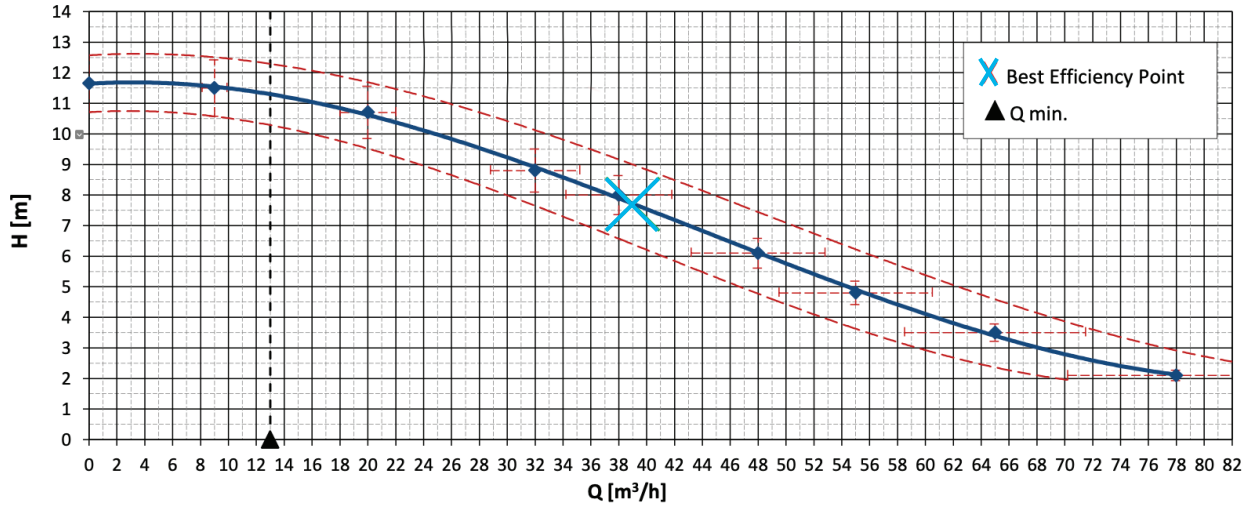

SHAFT POWER

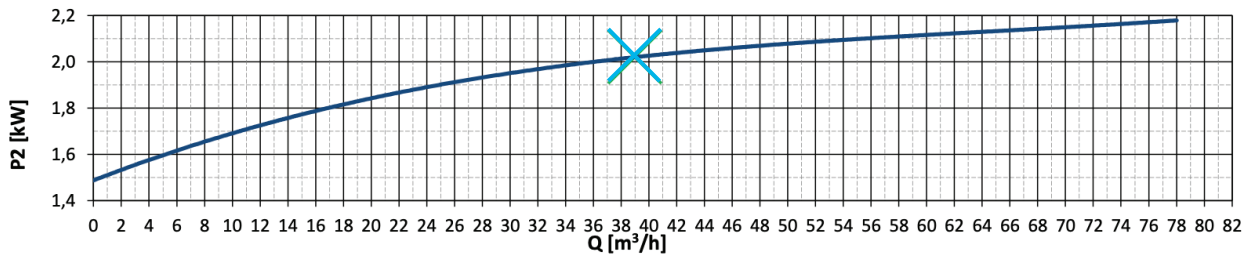

HYDRAULIC EFFICIENCY

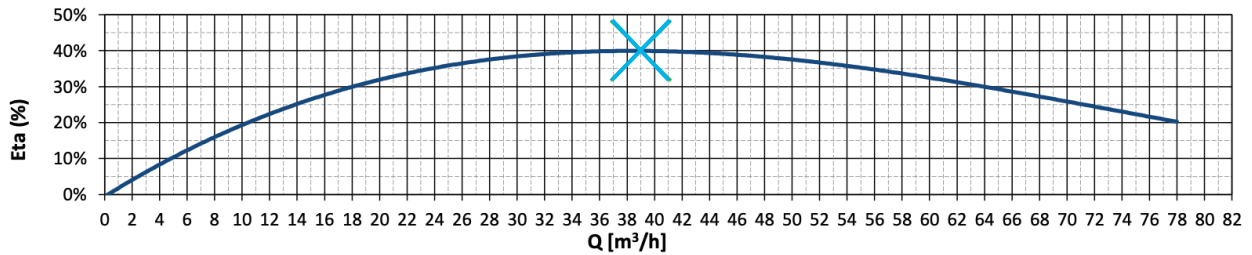

FLOW (Q)	l/min	0,0	150,0	333,3	533,3	633,3	800,0	916,7	1083,3	1300,0			
	l/s	0,0	2,5	5,6	8,9	10,6	13,3	15,3	18,1	21,7			
	m³/h	0,0	9,0	20,0	32,0	38,0	48,0	55,0	65,0	78,0			
HEAD (H)	m	11,7	11,5	10,7	8,8	8,0	6,1	4,8	3,5	2,1			

Specifications

Pump Type	VX80T	Discharge	80mm BSP	Humidity Probe	Yes
Code	VX80T4.942	Power Supply	3ph 400V - 50Hz	Cable Length	10m
Construction	Cast Iron	Nominal Speed	1450rpm	Max Flow	78m3/hr
Impeller Type	Vortex	Rated Motor Power	2.9kW	Max Head	11.7m
Weight	76kg	Starting Current	27A	Ingress Rating	IP68
Impeller diameter	219mm	Rated Current	5.2A		
Solids Passage	80mm	Thermal Protection	Yes		

Vortex Submersible Pump

VX80T2.942



Dimensions and installation

S Installation mobile

Packaging dimensions

Measures [mm]

A	B	C
750	450	390

FC With foot coupling

8FC000004

1	1 1/2 guide rails bracket
2	Vertical foot - 3" out
3	Sliding bracket complete
4	Not supplied

D

D	550
E	600
F	400